



# INSTALLATION INSTRUCTIONS

Accessory

UNDER COWL  
P/N 08F71-MKN-D50

Application

CB650RA

Publication No.

MII

Issue Date

September 2018

**Honda Dealer: Please give a copy of these instructions to your customer.**

## PARTS LIST

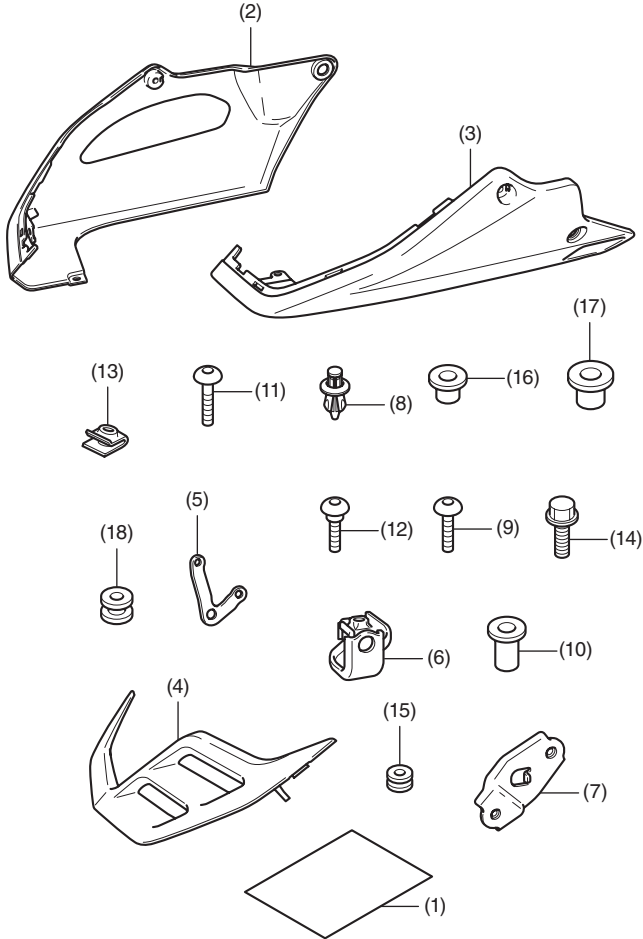

No.	Description	Qty
(1)	URL paper	1
(2)	Right under cowl	1
(3)	Left under cowl	1
(4)	Front under cowl	1
(5)	Front right stay	1
(6)	Front left stay	1
(7)	Rear left stay	1
(8)	Clip	1
(9)	5 mm screw	3
(10)	Well nut	2
(11)	6 mm screw	1
(12)	5 mm screw (stepped)	2
(13)	Clip nut	2
(14)	6 mm flange bolt	1
(15)	Rubber (small)	1
(16)	Collar (small)	1
(17)	Collar (large)	1
(18)	Rubber (large)	1

## TOOLS REQUIRED

- Socket (10 mm)
- Ratchet
- Hex wrench (5 mm)
- Torque wrench

## TORQUE CHART

Tighten all screws, bolts, and nuts to their specified torque values. Refer to the Service Manual for the torque values of the removed parts.

Item	N-m	kgf-m	lbf-ft
5 mm screw	4.2	0.4	3.1
6 mm screw	9	0.9	6.6
6 mm flange bolt	12	1.2	9

## INSTALLATION

### ▲ CAUTION

- To prevent burns, allow the engine, exhaust system, radiator, etc., to cool before installing the accessory.

1. Remove the drain stay as shown.

<Left side>

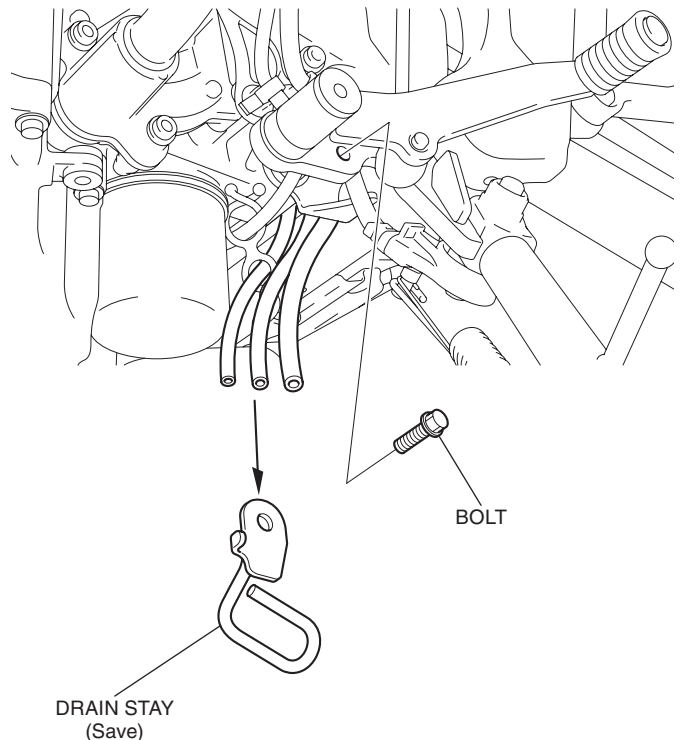

2. Install the front left stay as shown.

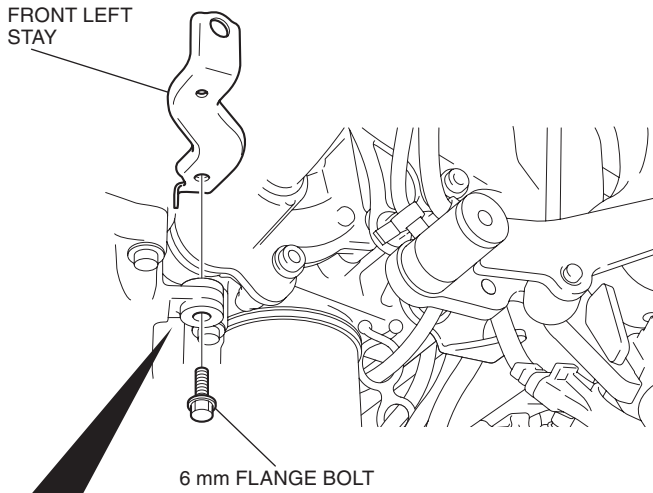

Contact the tab of the front left stay to the oil pan as shown.

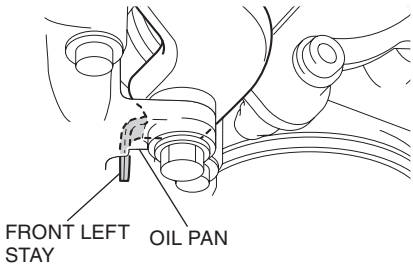

3. Install the rear left stay as shown.

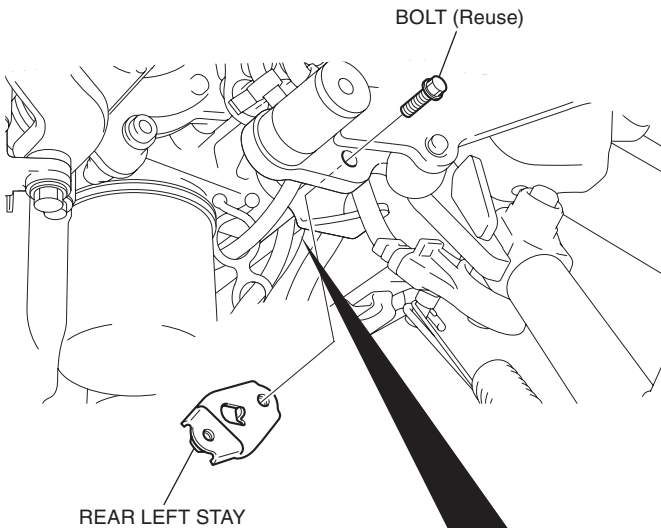

Contact the tab of the rear left stay to the stay as shown.

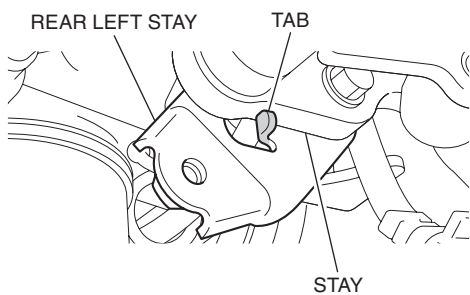

4. Install the well nut as shown.

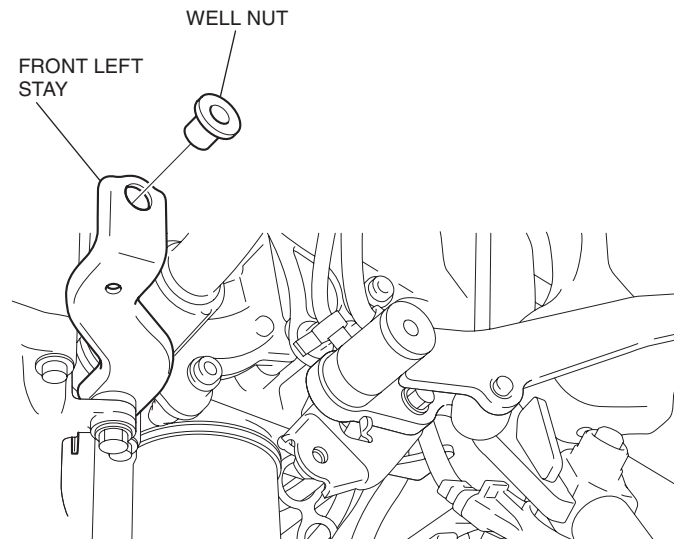

5. Remove the bolts as shown.

<Right side>

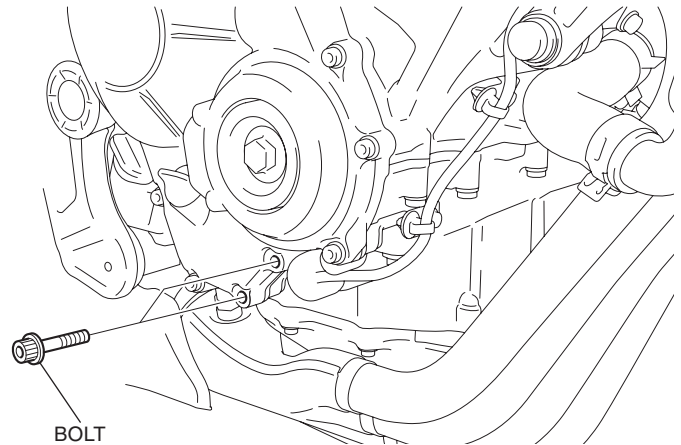

6. Install the front right stay as shown.

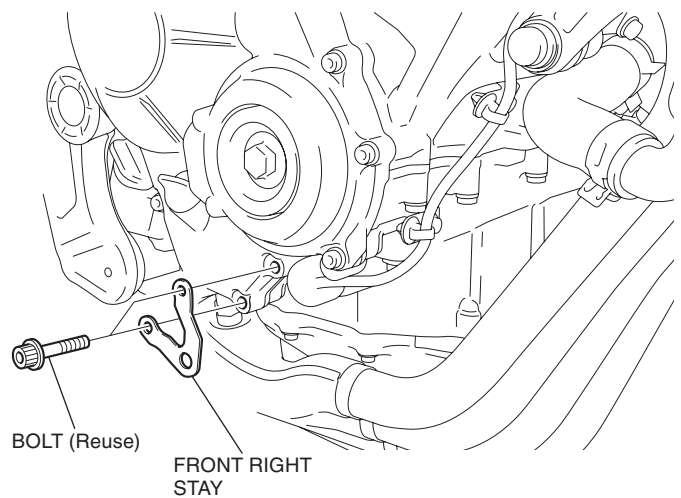

7. Install the well nut as shown.

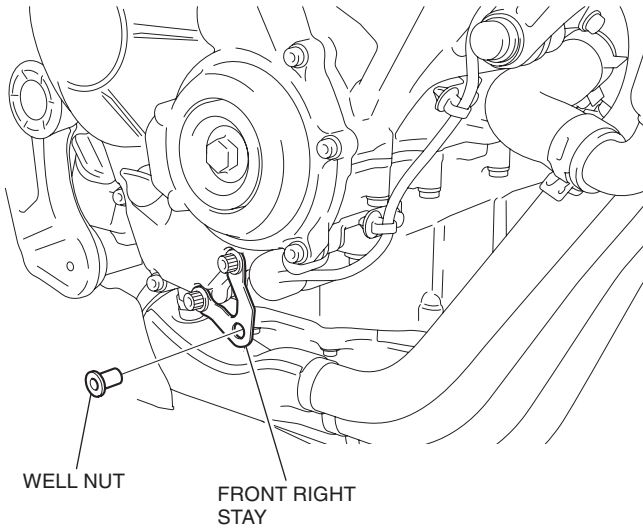

8. Install the clip nut and rubber as shown.

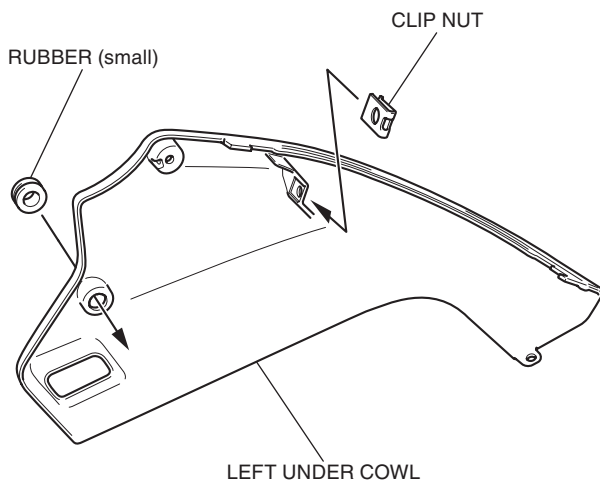

9. Install the clip nut and rubber as shown.

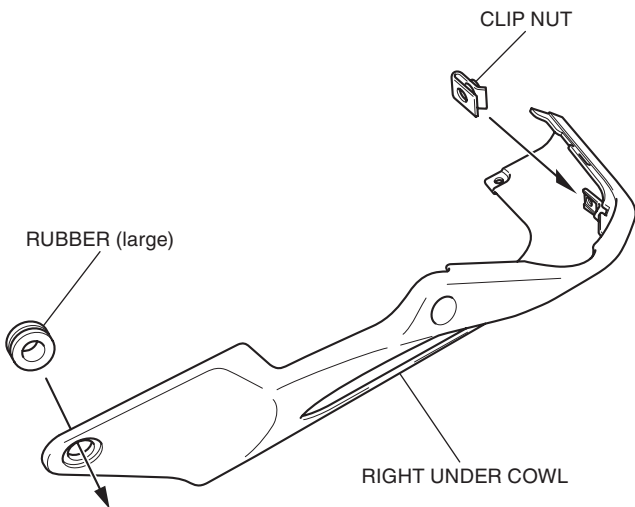

10. Assemble the right and left under cowls as shown.

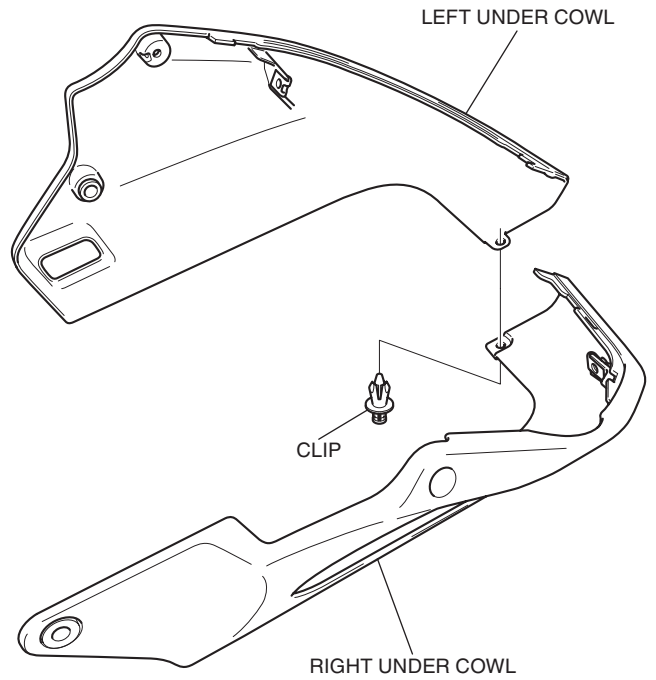

11. Install the front under cowl as shown.

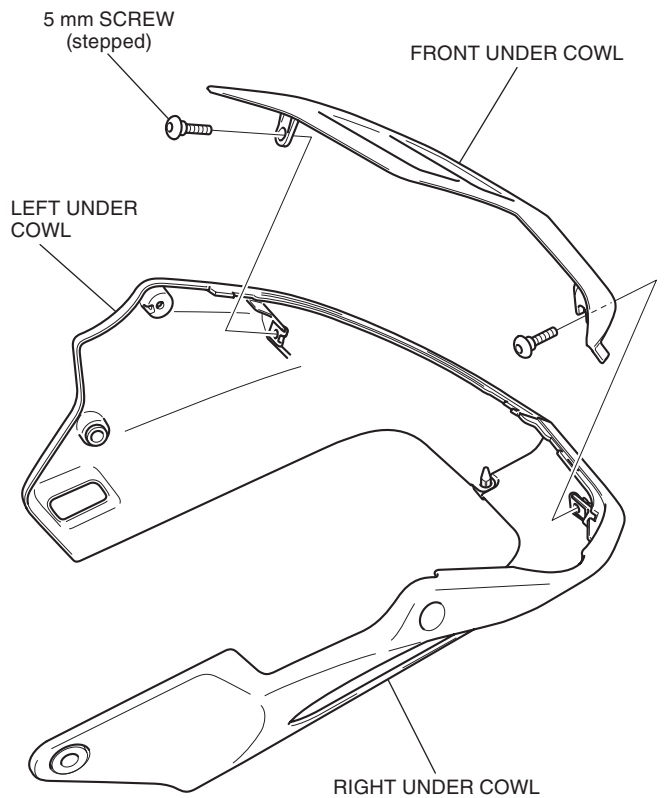

12. Install the collars as shown.

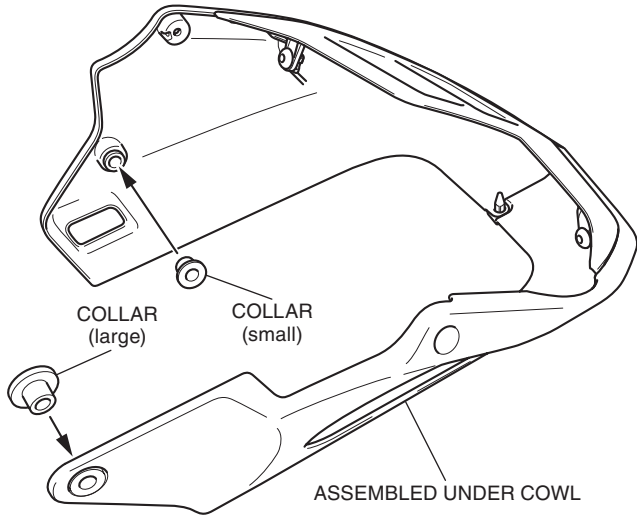

13. Loosely install the assembled under cowl as shown.  
<Left side>

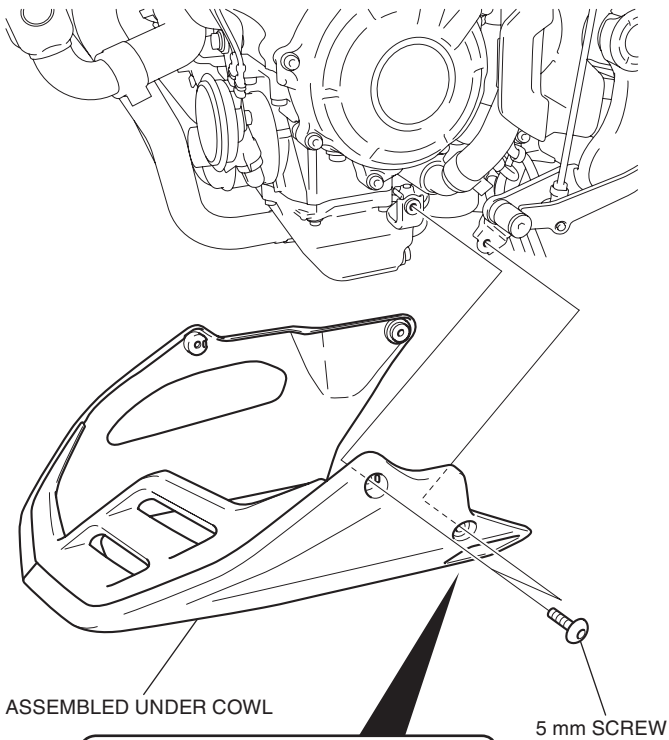

Pass the tubes through the hole of the under cowl as shown.

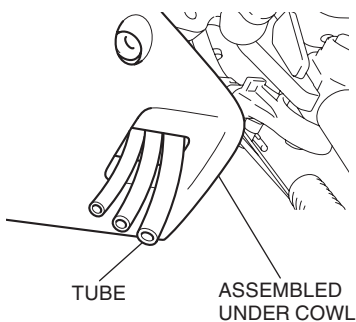

14. Loosely install the screws as shown.

<Right side>

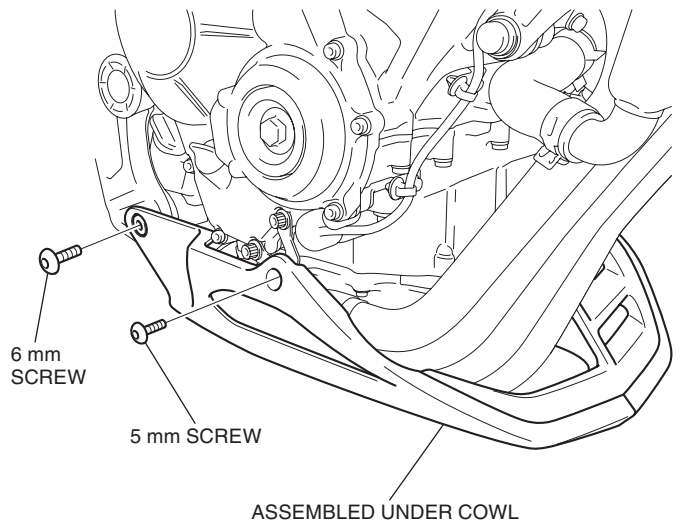

15. Tighten the screws as shown.

<Left side>

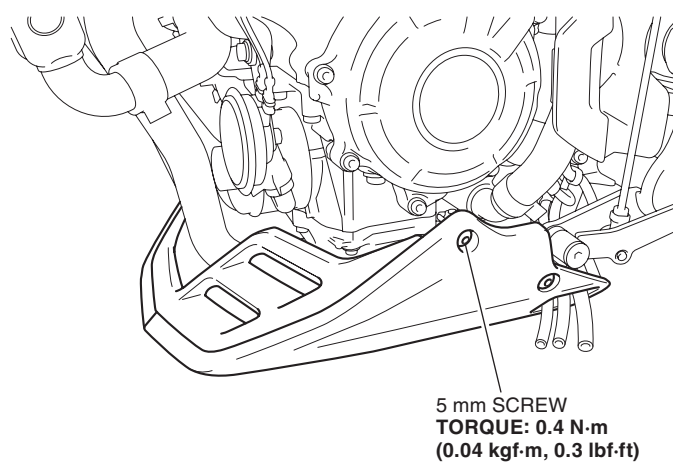

<Right side>

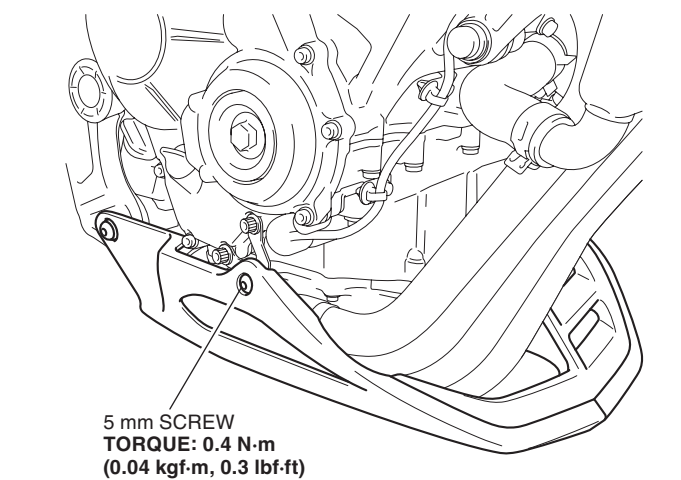

16. Tighten all loosely installed hardware to the specifications in the torque chart.